



PREVOR

AUTONOMOUS PORTABLE SHOWER **PROTECTIVE BOX**



Box:

Made with thermoplastic polypropylene.
Rigid, resistant to impact and cracking.
Rot-proof, polypropylene hinges.
Inert to aggressive atmospheres (petrochemical industry, marine...).
Equipped with a green door, watertight seal and a PC window.
Size: H 655 x L 314 x D 239 mm.
Weight: 2 kg (2.8 kg cardboard included).

INCLUDED ITEMS AND INSTRUCTIONS FOR INSTALLATION:

- Delivered items:

- A plastic box
- A DAP (not yet used)
- Descriptive signs (in the case of a new DAP)

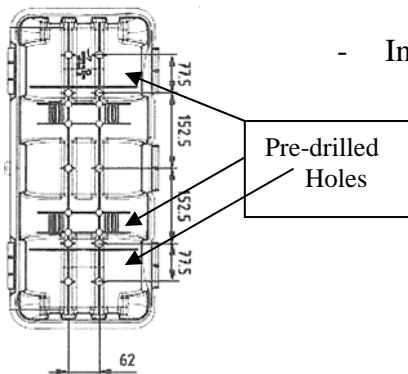

- Installation of the box in an accessible place, close to the risk:

- Take the DAP out of the box.
- Hang the box using pre-drilled holes in the box. The box **MUST** be placed with door hinges on the left side in order to guarantee water-tightness.
(Recommended height: the top of the box at 1.10m from floor).
- Replace the DAP, complete with the flexible hose, into the box and position the DAP with the label showing the name of the product, so that it can be seen through the window.
- Close the box with the 2 clasps and check the positioning of the door in order to guarantee water-tightness.

